

(No Model.)

G. LAYING.
APPARATUS FOR REVERSING ROTARY MOTION.

No. 406,586.

Patented July 9, 1889.

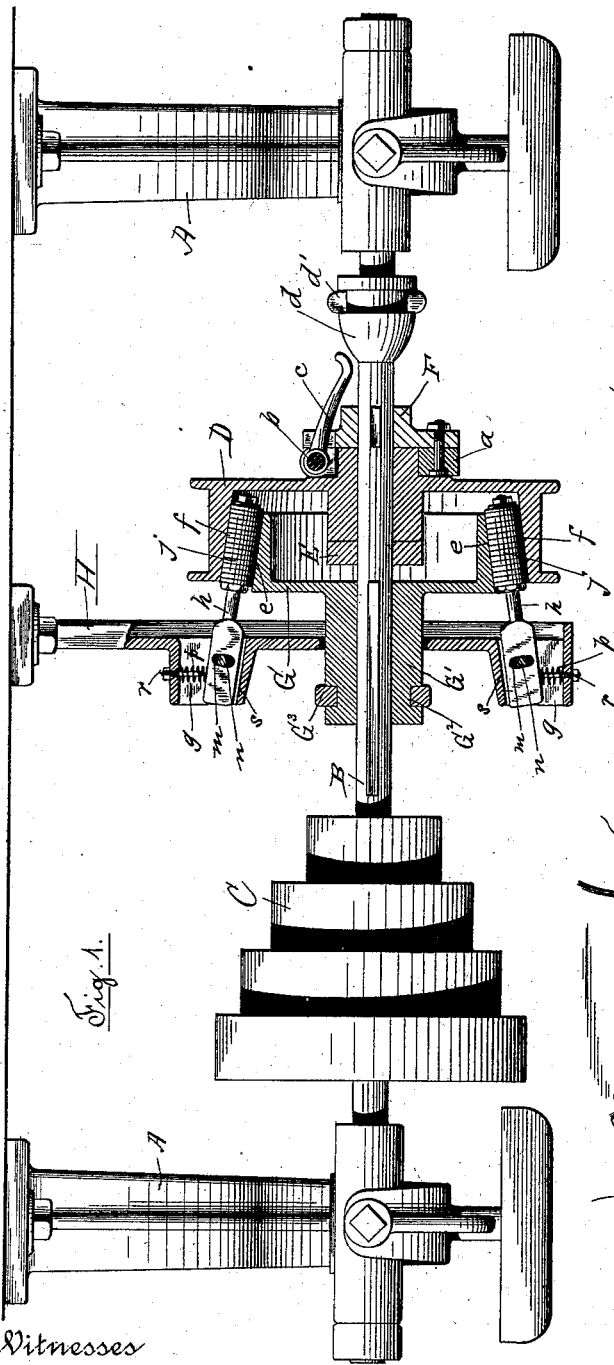

Fig. 1.

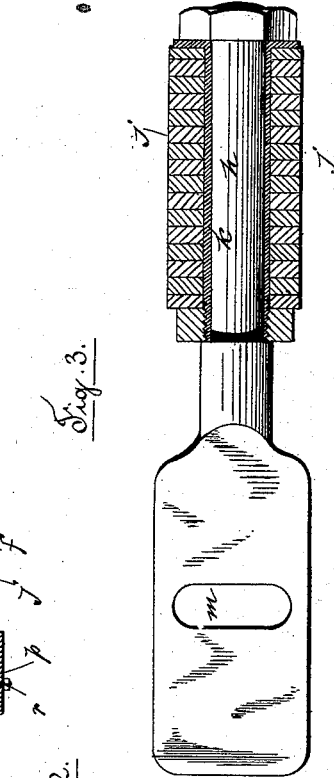

Fig. 2.

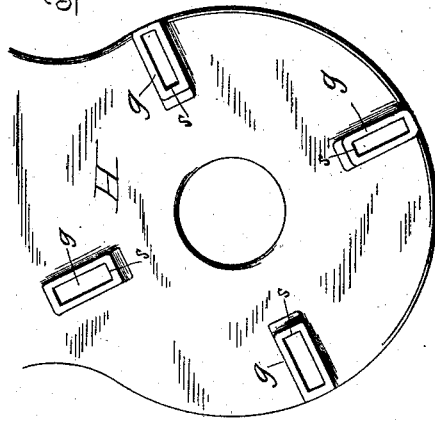

Fig. 3.

Witnesses
Chas. F. Schmetz,
H. M. Fowler

Inventor
George Laying,

By his Attorney
Rufus B. Fowler

UNITED STATES PATENT OFFICE.

GEORGE LAYNG, OF WORCESTER, MASSACHUSETTS, ASSIGNOR OF ONE-HALF
TO SILAS W. GODDARD, OF SAME PLACE.

APPARATUS FOR REVERSING ROTARY MOTION.

SPECIFICATION forming part of Letters Patent No. 406,586, dated July 9, 1889.

Application filed May 14, 1888. Serial No. 273,866. (No model.)

To all whom it may concern:

Be it known that I, GEORGE LAYNG, a citizen of the United States, residing at Worcester, in the county of Worcester and State of Massachusetts, have invented a new and useful Improvement in Apparatus for Reversing Rotary Motion, of which the following is a specification, containing a full, clear, and exact description of my invention, which is illustrated by accompanying drawings, in which—

Figure 1 represents a view of a counter-shaft employed in driving a metal-turning lathe, the part embodying my present invention being shown in central sectional view. Fig. 2 is a detached view of the supporting-frame for holding the intermediate friction-rolls; and Fig. 3 shows in an enlarged view one of the roll-spindles, with its roll shown in central sectional view.

Similar letters refer to similar parts in the several views.

My present invention relates to an apparatus for the purpose of reversing the rotary motion of metal-turning lathes, metal planers, and all varieties of machines in which it is required at times to reverse their motion. My invention, however, is only illustrated in the accompanying drawings as applied to the counter-shaft of a metal-turning lathe. Such modifications of construction and arrangement as may be necessary to accommodate my invention to other uses not shown or herein described will readily suggest themselves, and I have therefore not deemed it needful to illustrate or describe the embodiment of my invention further than to set forth its essential features.

In the drawings, A A denote the hangers; B the counter-shaft; and C a cone-pulley, from which power is communicated to a similar pulley on the lathe-spindle in the usual and well-known manner.

D denotes a belt-pulley running loosely upon the shaft B, and receiving its motion through a belt (not shown) from the main shaft. The pulley D is held in place by the collar E, attached to the shaft B, and the collar F, also attached to the shaft B and carrying the friction-clutching mechanism consisting of the elastic friction-strap *a*, inclosing the hub of the pulley D, and provided with the ro-

tating spindle *b*, with its lever *c*, which is raised by means of the sliding cone *d*, operated by the usual shipping devices *d'*. The friction-strap *a* is made to grasp the hub of the pulley and cause the rotary motion of the pulley to be imparted to the shaft B in the common and well-known manner; or, instead of the specific device shown, any other well-known clutching mechanism may be employed for the purpose of causing the motion of the pulley to be imparted to the shaft B. Upon the opposite side of the pulley B is a sliding cone-pulley G, provided with a long hub G', having an annular groove G² to receive a shipper G³. The face of the pulley G is slightly tapering, as shown at *e e*, and the inner surface of the flange of the belt-pulley D is tapered at *f f* to correspond with the outer surface of the pulley G.

H is a frame-work, in the present case suspended from the ceiling, and provided with the four equidistant mortises *g g g g*, to receive the roll-spindles *h h*, four in number and arranged concentrically about the shaft B, two of which only are shown. Upon the inner and free ends of the roll-spindles *h* are the rolls *j*, preferably made of rawhide, leather, vulcanized fiber, or some analogous material, in the form of disks pressed upon a sleeve *k*, Fig. 3, which runs freely upon the roll-spindle *h*. The roll-spindles are flattened where they enter the mortises *g*, and are provided with elongated holes or slots *m m*, through which the pivotal pins *n n* pass. Spiral springs *p p*, held upon the bolts *r r*, press against the outer edges of the flattened sections of the roll-spindles *h*, serving to press them against the sides *s s* of the mortises *g*, when the internal pulley G is removed from the belt-pulley B. The sliding cone *d* and the hub G' of the pulley G are preferably connected with the same shipping device, so they may be operated simultaneously, the sliding cone being carried beneath the lever *c* at the same time the cone-pulley G is carried out of the belt-pulley B.

The operation of my reversing apparatus is as follows: In the operation of turning or screw-cutting the cone *d* is carried beneath the lever *c* and the friction-strap made to engage the hub of the pulley B, causing the

rotary motion of the pulley to be imparted to the shaft B. Whenever it is desired to reverse the motion of the lathe, the cone *d* is removed from beneath the lever *c*, disengaging the friction-clutch, and at the same time carrying the cone-pulley G into the pulley D and bringing the rolls *j* into contact with the tapering surfaces *e* and *f*. The rotary motion of the pulley D is then imparted to the pulley G through the intermediate rolls *j*, giving a reverse motion to the pulley G, which has a spline-connection with the shaft B, thereby conveying a reverse rotary motion to the shaft and the lathe. The cone *d* and cone-pulley G are so arranged that as they are simultaneously shipped the cone *d* will move out from beneath the lever *c* slightly in advance of the engagement of the cone-pulley G, allowing the pulley D to be entirely disconnected from the shaft B. As the roll-spindles are pivoted on the pins *n* through the slotted openings *m*, they are readily brought into alignment with the tapering surfaces of the pulleys D and G, and as the cone-pulley G is withdrawn from the pulley D the roll-spindles are pressed against the edges *s* of the mortises *g* and holding the rolls in a position midway between and out of contact with the tapering surfaces *e* and *f*. When the shaft B is driven by the pulley D through the clutch device acting upon the hub of the pulley, the angular velocity of the shaft and pulley will be equal; but when the shaft is driven through the intermediate rolls and pulley G, the circumferential speed of the two tapering surfaces *e* and *f* will be the same and the angular velocity of the pulley G will be greater than that of the pulley D, as its diameter is less than that of the pulley D. This difference in the diameters of the two pulleys D and G causes a quick reverse motion of the lathe, which is usually desired in running the tool-carriage back in order to renew the operation of cutting.

The difference between the diameters of the two pulleys D and G may be increased or diminished in order to vary the speed of the reverse motion of the shaft B, and the diameters of the intermediate rolls enlarged or decreased to fill the space between the two tapering surfaces *e* and *f*. As the taper of the surfaces *e* and *f* is slight, the motion of the pulley G along the shaft enables the operator, by the use of an ordinary shipping-lever, to wedge the rolls *j* firmly between the surfaces *e* and *f* with a pressure sufficient to transmit all the power required to the lathe. As all the surfaces in contact roll upon each other, the friction of my device is small and its action is noiseless. As applied to the counter-shafts of metal-turning lathes it obviates the use of the double set of pulleys and belts with

their varying tractile power; and my device may be readily applied to metal-planing machines to effect their reverse movement, and also to many other classes of machines, by means of such modifications in its construction and arrangement as will be obvious to any one familiar with the construction of machinery.

What I claim as my invention, and desire to secure by Letters Patent, is—

1. In an apparatus for reversing rotary motion, the combination, with a shaft and a pulley running loosely thereon and provided with an internally-tapering flange, of a conical pulley having a spline-connection with said shaft, but capable of sliding thereon, and a series of intermediate rolls placed between the tapering surfaces of said pulleys, whereby the rotary motion of one pulley is made to impart a reverse rotary motion to the other pulley, substantially as described.

2. The combination, with a pulley running loosely on its shaft and a pulley having a spline-connection, but capable of sliding on the same shaft, of a series of rolls intermediate the inner and outer faces of said pulleys, substantially as described, said rolls being held on spindles pivoted in a supporting-frame, so the axes of said rolls may be brought into true alignment with the opposing faces of said pulleys, substantially as described.

3. The combination, with pulleys D and G and rolls *j*, arranged substantially as described, of a rigid frame held in a fixed position, and spindles pivoted in said fixed frame and carrying said rolls *j*, substantially as described.

4. The combination, with pulleys D and G, provided with opposing faces, and rolls *j*, placed between said faces, of supporting-frame H, with mortises to receive the roll-spindles, and springs applied to said roll-spindles, whereby said rolls are held from contact with the opposing surfaces of said pulleys when the same are separated, substantially as described.

5. The combination, with a shaft and a pulley running loosely around said shaft and being provided with clutching mechanism, whereby its motion is imparted to said shaft, of a pulley having a spline-connection and sliding on said shaft, said pulleys having opposing parallel faces inclined to the axis of their rotation, and rolls placed between said inclined faces, whereby the rotary motion of one pulley is made to impart a reverse rotary motion to the other pulley, substantially as described.

GEORGE LAYNG.

Witnesses:

RUFUS B. FOWLER,
CHAS. F. SCHMELZ.